

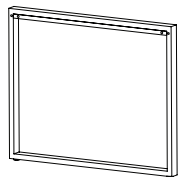



IM A4 size: Front page

BOLERO

DS157 Bolero Steel & Acacia Industrial Table (1800 x 900mm)
DS158 Bolero Steel & Acacia Industrial Bench (1600 x 380mm)

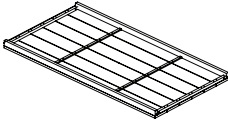
A	 x 2	C	 x 4 DS157/DS158: M10.5 x 1.5 mm
B	 x 1	D	 x 4 DS157/DS158: M10 x 40 mm
		E	 x 1 Key 17

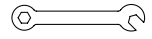

UK	0845 146 2887	Fourth Way, Avonmouth, Bristol, BS11 8TB United Kingdom
NL	0800 – 29 1 29	
	040 – 2628080	
FR	0800 - 29 2 29	
	01 60 34 28 80	
DE	0800 – 1860806	
IT	N/A	
ES	901-100 133	
PT	vendas@nisbets.pt	
AU	1300 225 960	15 Badgally Road, Campbelltown, 2560, NSW, Australia

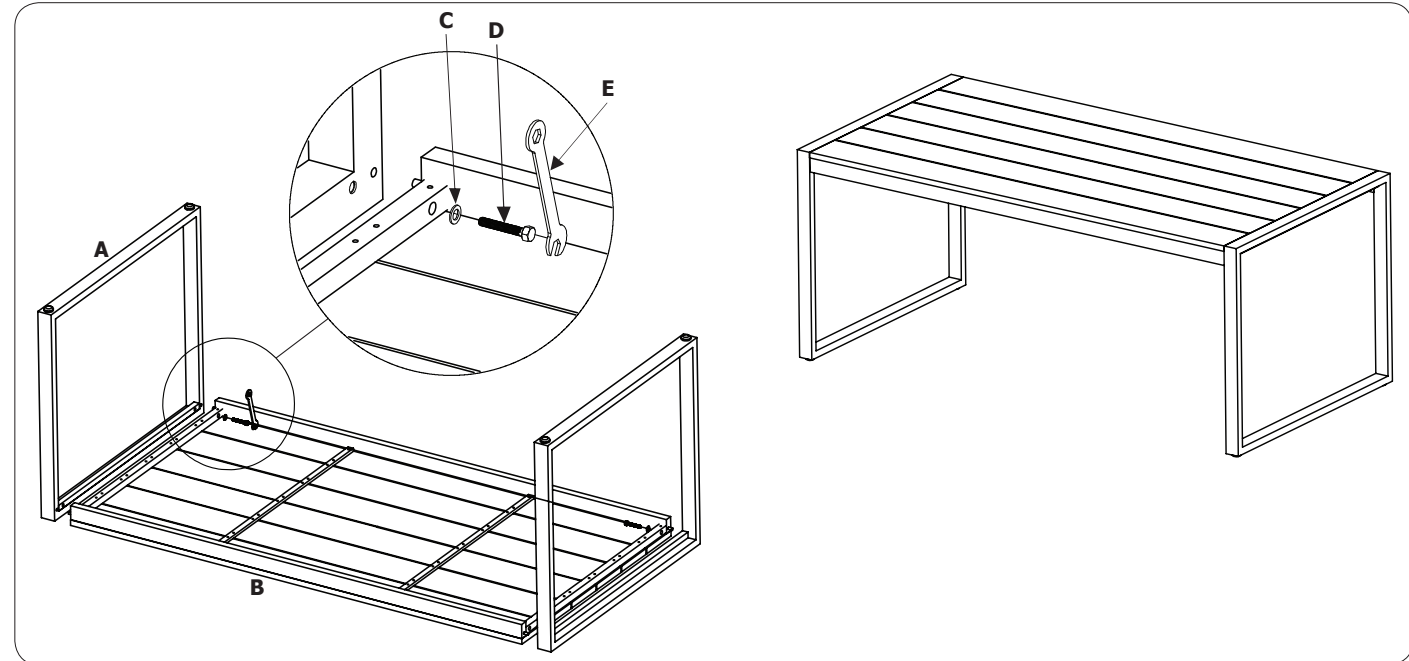

Important:

- Ensure the bench is assembled correctly and all bolts are tightened
- Please periodically check and tighten all fixings
- Do not tilt forwards or backwards on the bench

Furniture Maintenance:

Wood is a natural material whose appearance will deteriorate when left outside. A surface coating is vital in protecting it from premature cracking / splitting of wood, when exposed to the weather. The finish should be regularly maintained to ensure that the wood is protected from moisture and the furniture continues to look its best.

In order to maintain the appearance of the wood, regular coatings of teak oil (DL476) should be applied in accordance with the instructions supplied with the oil. The frequency will depend on the weather conditions experienced.

If positioned in an exposed position, we recommend the use of a parasol to prevent oils from drying out and flaking.

This will help maintain the appearance of the table surface.

In order to maintain its appearance, this wooden furniture should be protected from severe weather and stored under cover during winter. A liberal coating of Oil should be given to the furniture before it is laid up and again when it is removed from storage.

Should you choose not to treat your furniture then it will turn a greyish colour and develop cracks. Light sanding can restore the original colour after which teak Oil can be regularly applied in accordance with the instructions above.

DS157-DS158_A4_v2_20190325